

## **A VERSATILE DATA ACQUISITION SYSTEM FOR USE WITH THERMAL ANALYSIS EQUIPMENT**

J.B. HENDERSON and D.L. MENDELSON

*Department of Mechanical Engineering and Applied Mechanics, University of Rhode Island, Kingston, RI 02881 (U.S.A.)*

(Received 15 November 1983)

### **ABSTRACT**

A versatile digital data acquisition system has been interfaced with a Netzsch high temperature thermal analysis system. The system hardware consists of a commercially available data logger, a microcomputer, and the thermal analysis equipment. The utility of the system was demonstrated by studying the kinetics of decomposition of a fiberglass-filled acrylonitrile–butadiene (AB) copolymer. Experimental thermogravimetric data were obtained at four heating rates for both the initial pyrolysis reactions below 1000°C and the high temperature carbon–silica reactions above 1000°C. From these data the kinetic parameters for both reaction regions were calculated using a multiple heating rate technique proposed by Friedman. The results obtained using the data acquisition system were satisfactory.

### **INTRODUCTION**

Most manufacturers of thermal analysis instrumentation market either chart recorders or digital data acquisition systems for use with their equipment. The primary drawback of the chart recorders is the inordinate amount of time required to process the experimental data. In contrast, the digital data acquisition systems are fast and reliable. These systems are generally of high quality and function quite well with the equipment for which they were designed. They are, however, quite expensive and, in many cases, their use is limited to the manufacturer's equipment. Additionally, the software required to process the data of interest is usually available only through the manufacturer and is also quite expensive.

The purpose of this paper is to describe an extremely versatile digital data acquisition system for use with any type of thermal analysis equipment. Because of its versatility, the system may also be used for any number of general laboratory functions. The data acquisition system contains standard, commercially available, components, consisting of a data logger interfaced with a microcomputer with peripheral units. The system monitors the analog millivolt signals from the thermal analysis system, digitizes them at specified

time increments, converts the data into physically significant quantities, and outputs the data to the desired peripheral unit. Manipulation and storage of the data are accomplished using two separate computer programs.

#### THERMAL ANALYSIS SYSTEM

The thermal analysis system consists of a Netzsch Model 409/6 simultaneous thermal analyzer (STA) and a Netzsch Model 402 ES/3, low load, ball bearing dilatometer. In addition to operating as an STA, the 409/6 can be operated either as a thermogravimetric analyzer (TGA) or as a differential thermal analyzer (DTA). The STA and dilatometer units are capable of operation to 1750 and 1600°C, respectively. Temperature control of both the units is provided by a Netzsch Model 413 programmer and Model 413 controller. The control system also contains several amplifiers which are utilized by both units. The analog output voltage from the control unit corresponds to temperature, weight loss, rate of weight loss and differential temperature for the STA, and temperature, length change and rate of length change for the dilatometer.

#### DATA ACQUISITION SYSTEM

##### *Hardware*

The data acquisition system consists of several pieces of general purpose laboratory equipment. The system digitizes the appropriate analog data from the Netzsch thermal analysis system at specified intervals of time using a Monitor Labs model 9302, 40 channel data logger. The data logger transmits the digitized data to an Apple II Plus microcomputer, via a standard RS-232-C connector and an Apple serial interface card. The data is then processed by the microcomputer and output to one or more of the peripheral units, which consist of a floppy disk drive, printer and a model DMP29 Houston Instruments plotter. The peripheral units are linked to the Apple by standard serial and parallel interface connections. The schematic of the thermal analysis equipment and data acquisition system is shown in Fig. 1.

##### *Software*

Three separate computer programs are utilized by the data acquisition system. These consist of a data acquisition program, an STA conversion program, and a dilatometer conversion program. The STA program treats STA, TGA, or DTA data depending on the mode of operation of the STA unit. Only the data acquisition and STA conversion programs will be discussed here.

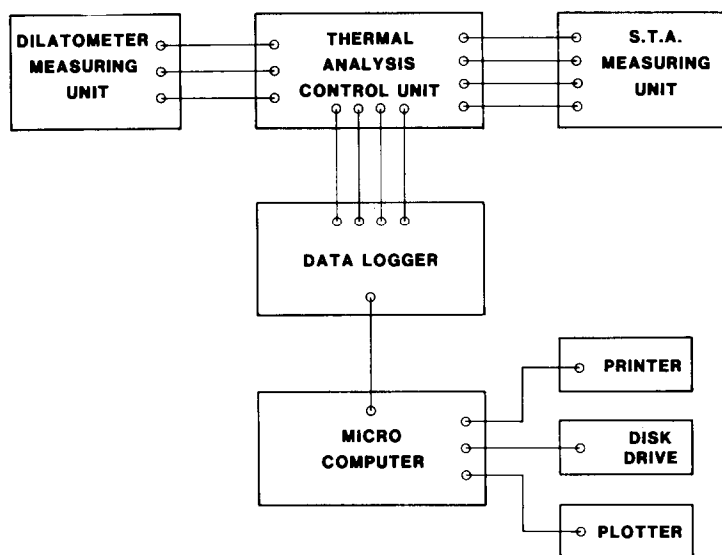

Fig. 1. Hardware schematic for thermal analysis equipment and data acquisition system.

The data acquisition program performs three distinct functions. These are the acquisition of the data from the data logger, conversion to numerical quantities from character form, and storage and printing of the converted data. The data acquisition is performed with the help of two subroutines which retrieve the data from the data logger in character form. These routines are supplied with the data logger and are presented in the Monitor Labs 9302/Apple microcomputer support manual [1]. The conversion to numerical values is accomplished by software which evaluates predetermined bytes of the input character. The conversion portion of the program also displays the characters on the monitor along with the elapsed time of the experiment. When the designated number of iterations has been performed, the data is stored in a random access file and a hard copy of the raw data is printed.

The STA program converts the raw millivolt data into physically significant quantities and interpolates to even increments of the fraction of weight remaining. The program first reads the experimental millivolt data and the thermocouple conversion data from their respective files. The thermocouple conversion file contains millivolt vs. temperature data at  $10^{\circ}\text{C}$  intervals from 0 to  $1820^{\circ}\text{C}$  for platinum-6% rhodium vs. platinum-30% rhodium thermocouples. The millivolt data representing the temperature and differential temperature are converted to actual temperature and differential temperature by a linear interpolation between these thermocouple conversion data points. The fraction of weight remaining and derivative of weight loss are obtained from the millivolt data by using the appropriate conversion factors. The elapsed time of the experiment is also calculated by the program. Once the data have been converted they are linearly interpolated to even incre-

ments of the fraction of weight remaining. The interpolated data are then stored in a second random access file for future use and both the converted and interpolated data are printed. Finally, the interpolated data are plotted as a function of temperature. A flow chart of the data acquisition and STA conversion programs is presented in Fig. 2.

EXPERIMENTAL

*Material*

The composite ablative material used in this work, MXBE-350, was

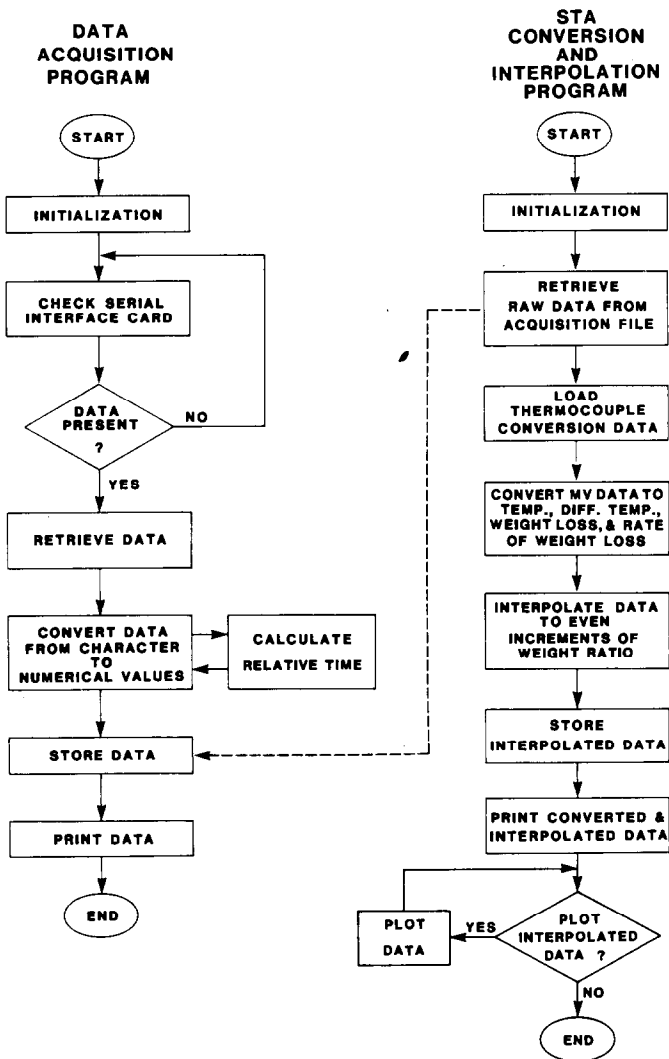

Fig. 2. Flow charts for computer programs.

supplied by Fiberite Corporation. The material is a fiberglass filled acrylonitrile–butadiene (AB) copolymer consisting of approximately 56.5% glass powder and fiberglass and 43.5% resin. The samples were tested in powder form and were obtained by machining larger blocks of material. Samples were stored overnight in a vacuum desiccator maintained at 35°C to remove traces of moisture.

This material is of practical interest since it is used in a number of thermal protection applications. The material undergoes two different types of reactions, both of which result in a significant weight loss. The first are the low temperature pyrolysis reactions of the resin matrix. These are followed by high temperature carbon–silica reactions between the glass filler and the carbon residue from the pyrolysis reactions. Details of the kinetics of these reactions have been described previously by Henderson et al. [2] and Henderson and Tant [3].

### *Procedure*

The STA unit, depending on the mode of operation, outputs up to four channels of analog millivolt data. In this work the unit was operated in the TGA mode and therefore only three channels of data representing temperature, weight loss, and rate of weight loss were monitored.

In order to reduce temperature gradients and ensure uniform heating, powdered samples of the material were tested. The resin was prevented from thermo-oxidatively degrading by maintaining the samples in an argon atmosphere throughout the experiment. Samples weighing  $48.0 \pm 1.0$  mg were tested from 40°C to approximately 1700°C at heating rates of 5, 10, 20 and 50°C min<sup>-1</sup>. The three channels of millivolt data from the STA unit were monitored by the data logger throughout the experiment. The data were digitized at 120, 60, 30 and 15 s intervals for the heating rates of 5, 10, 20 and 50°C min<sup>-1</sup>, respectively.

## RESULTS

The data were interpolated to 0.01 intervals of the fraction of weight remaining by the STA program. Figures 3 and 4 were reproduced from these data. Figure 3 shows the fraction of weight remaining as a function of temperature for all four heating rates. As shown, the low temperature pyrolysis reactions occur primarily between 200 and 600°C, while the carbon–silica reactions occur above 1200°C. Figure 4 shows the corresponding derivative of weight loss normalized with respect to the heating rate. The digitized experimental data are presented in Table 1.

The kinetic parameters for both sets of reactions were calculated by a

TABLE 1  
Experimental data

$w/w_0$	Heating rate 50°C min <sup>-1</sup>		Heating rate 20°C min <sup>-1</sup>		Heating rate 10°C min <sup>-1</sup>		Heating rate 5°C min <sup>-1</sup>	
	$T(^{\circ}\text{C})$	$-\frac{1}{w_0} \times \frac{dw}{dt} \times 10^{-3}$ (min <sup>-1</sup> )	$T(^{\circ}\text{C})$	$-\frac{1}{w_0} \times \frac{dw}{dt} \times 10^{-3}$ (min <sup>-1</sup> )	$T(^{\circ}\text{C})$	$-\frac{1}{w_0} \times \frac{dw}{dt} \times 10^{-3}$ (min <sup>-1</sup> )	$T(^{\circ}\text{C})$	$-\frac{1}{w_0} \times \frac{dw}{dt} \times 10^{-3}$ (min <sup>-1</sup> )
1.00	80	3.06	90	0.00	40	0.00	40	0.00
0.99	266	7.61	248	2.66	238	0.98	206	0.00
0.98	312	16.09	300	6.40	275	2.95	257	1.44
0.97	346	22.08	329	9.31	309	2.93	290	1.50
0.96	367	30.16	351	12.43	331	7.07	320	0.93
0.95	381	37.83	366	17.74	350	7.27	339	3.31
0.94	393	48.04	375	24.55	360	13.05	352	5.38
0.93	400	59.43	382	31.57	368	17.02	361	7.25
0.92	406	71.27	389	38.41	375	19.46	367	9.70
0.91	412	83.10	394	42.96	381	21.28	374	12.14
0.90	417	93.89	398	47.51	386	23.07	379	13.07
0.89	421	104.31	403	51.20	391	24.81	385	13.99
0.88	426	114.72	407	51.85	396	26.55	390	14.19
0.87	435	123.87	412	52.52	400	27.00	394	13.89
0.86	436	124.88	417	52.16	405	26.94	399	13.60
0.85	441	125.90	422	50.97	409	26.79	403	12.83
0.84	447	126.87	427	49.75	415	26.04	406	11.86
0.83	452	126.59	433	48.43	420	25.28	411	11.04
0.82	457	126.33	439	47.09	426	24.36	417	10.86
0.81	462	126.06	444	45.33	430	23.27	423	10.68
0.80	468	122.74	450	43.27	435	22.06	429	9.24
0.79	475	119.22	456	40.48	442	19.93	435	7.61

0.78	481	115.71	462	36.92	448	17.58	444	5.50
0.77	489	108.58	471	31.66	456	14.05	454	4.49
0.76	497	100.96	481	24.45	467	10.08	470	2.46
0.75	510	78.42	495	15.72	482	6.47	492	1.20
0.74	528	56.59	518	8.45	505	3.85	543	0.00
0.73	552	37.13	555	3.40	550	0.00	671	0.77
0.72	600	16.70	667	1.22	659	0.00	817	1.18
0.71	716	3.48	854	0.00	816	0.35	1050	1.12
0.70	973	3.10	1167	0.73	1038	0.19	1177	0.00
0.69	1322	1.49	1300	1.34	1194	0.57	1255	0.39
0.68	1408	6.51	1366	4.13	1285	1.33	1297	1.95
0.67	1450	12.77	1400	7.36	1326	3.63	1322	2.21
0.66	1480	21.43	1424	9.71	1354	4.10	1342	2.94
0.65	1495	27.11	1439	13.33	1371	5.72	1357	2.74
0.64	1511	31.46	1453	14.26	1385	7.03	1368	3.72
0.63	1520	38.80	1462	17.30	1396	9.18	1378	4.93
0.62	1529	42.81	1472	20.15	1407	10.55	1389	4.99
0.61	1538	46.96	1483	22.35	1416	10.82	1397	7.80
0.60	1546	53.28	1491	23.94	1424	11.39	1403	5.99
0.59	1554	59.57	1498	25.60	1431	12.82	1410	5.69
0.58	1560	62.85	1503	27.69	1437	14.28	1417	7.00
0.57	1569	64.60	1509	28.89	1443	14.75	1422	7.45
0.56	1580	63.49	1517	28.05	1449	14.77	1427	7.94
0.55	1588	63.19	1524	28.68	1455	14.28	1432	6.86
0.54	1613	32.13	1536	18.99	1463	12.39	1440	8.67
0.53	1657	14.81	1560	5.35	1476	6.47	1454	3.78
0.52	1681	0.00	1607	3.82	1511	2.05	1486	1.22
0.51	-	-	1663	1.76	1572	0.94	1617	1.28
0.50	-	-	-	-	1642	1.43	1679	0.00
0.49	-	-	-	-	1681	2.85	-	-

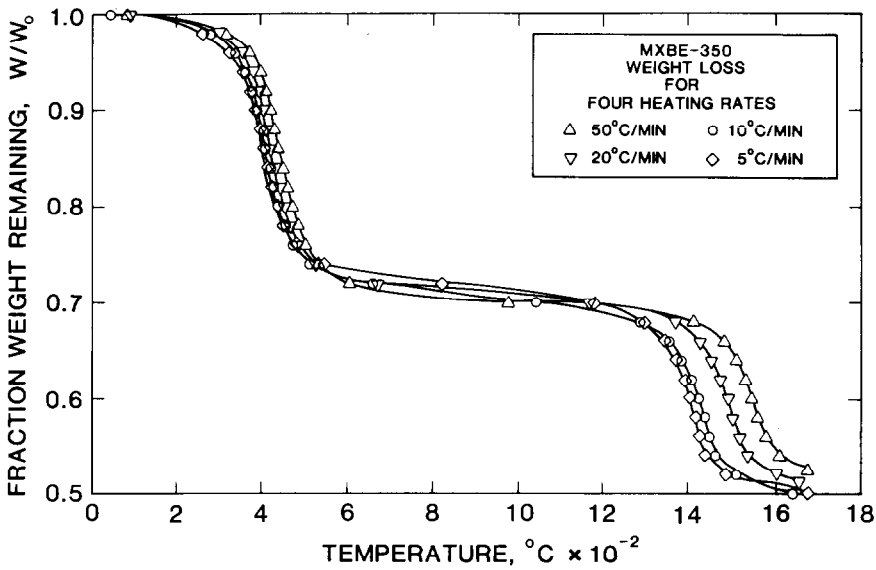

Fig. 3. Fraction of weight remaining.

multiple heating rate technique proposed by Friedman [4] using the following form of the kinetic rate equation

$$-1/w_0 \times dw/dt = A[(w - w_f)/w_0]^n \exp(-E/RT)$$

where  $w_0$  = original weight (mg),  $w_f$  = final weight (mg),  $w$  = instantaneous

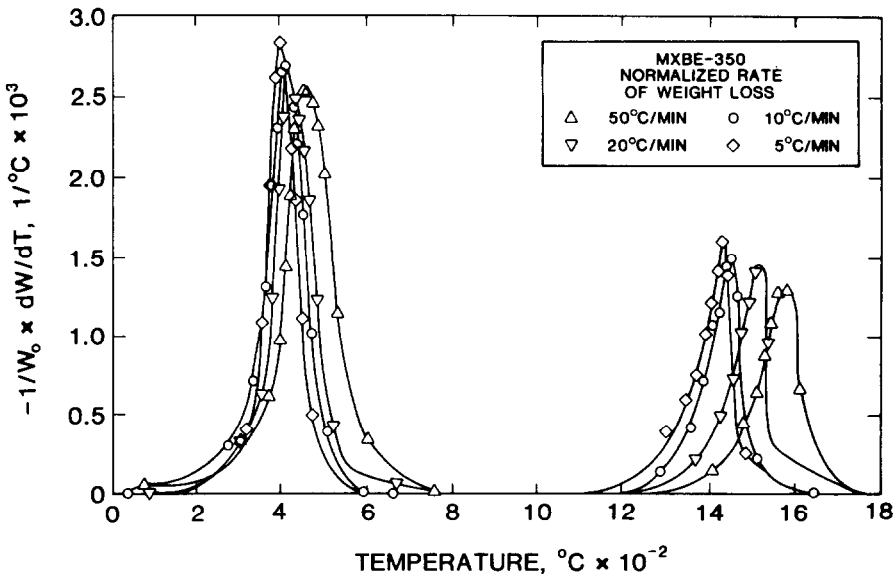

Fig. 4. Normalized rate of weight loss.



weight (mg),  $T$  = temperature (K),  $t$  = time (min),  $A$  = pre-exponential factor ( $\text{min}^{-1}$ ),  $E$  = activation energy ( $\text{cal gmol}^{-1}$ ),  $n$  = order of reaction (dimensionless),  $R$  = gas constant ( $1.987 \text{ cal gmol}^{-1} \text{ K}^{-1}$ ). This technique has been discussed in detail by Friedman [4] and Henderson et al. [2,3] and will not be repeated here.

A set of kinetic parameters consisting of the activation energy, pre-exponential factor and order of reaction were calculated for the pyrolysis and carbon-silica reactions, respectively. The average activation energy for the pyrolysis reactions were calculated from experimental data covering the range of weight loss  $0.77 \leq w/w_0 \leq 0.98$ . Two sets of pre-exponential factors and orders of reaction were required for the pyrolysis reactions, one for  $0.96 \leq w/w_0$  and another for  $w/w_0 < 0.96$ . This technique has been described by Henderson et al. [2]. Calculation of the kinetic parameters for the carbon-silica reactions was straightforward and was based on experimental data in the weight loss range  $0.55 \leq w/w_0 \leq 0.67$ . Experimental data outside these ranges were excluded because of scatter due to the low rates of weight loss. The final weight ratio,  $w_f/w_0$ , was taken as 0.7 for the pyrolysis reactions and was calculated for the carbon-silica reactions by averaging the final weight ratio for all four heating rates at approximately  $1676^\circ\text{C}$ . A summary of the calculations for both sets of reactions is presented in Table 2.

The kinetic parameters presented in Table 2 were used in the kinetic rate equation to calculate the fraction of weight remaining vs. temperature. Each set of parameters was applied to the portion of the curve from which it was determined. A comparison of the calculations and the experimental data are shown in Fig. 5 for all four heating rates. As shown, the calculated thermograms closely reproduce the experimental data.

## DISCUSSION

As shown by the results of the TGA measurements on the composite material, the system functions quite well. The millivolt data from the thermal analysis system was converted quickly and accurately. This provides a significant advantage over strip chart recorders, in that only a few minutes

TABLE 2  
Summary of calculations

Reaction	$w_f/w_0$	Range of $w/w_0$	$E_{av}$ ( $\text{kcal gmol}^{-1}$ )	$A$ ( $\text{min}^{-1}$ )	$n$	$w/w_0$
Pyrolysis	0.70	0.98-0.77	52.6	$1.49 \times 10^{46}$	50.64	$\geq 0.96$
				$5.08 \times 10^{18}$	4.20	$< 0.96$
Carbon-silica	0.505	0.67-0.55	81.6	$5.19 \times 10^8$	0.21	-

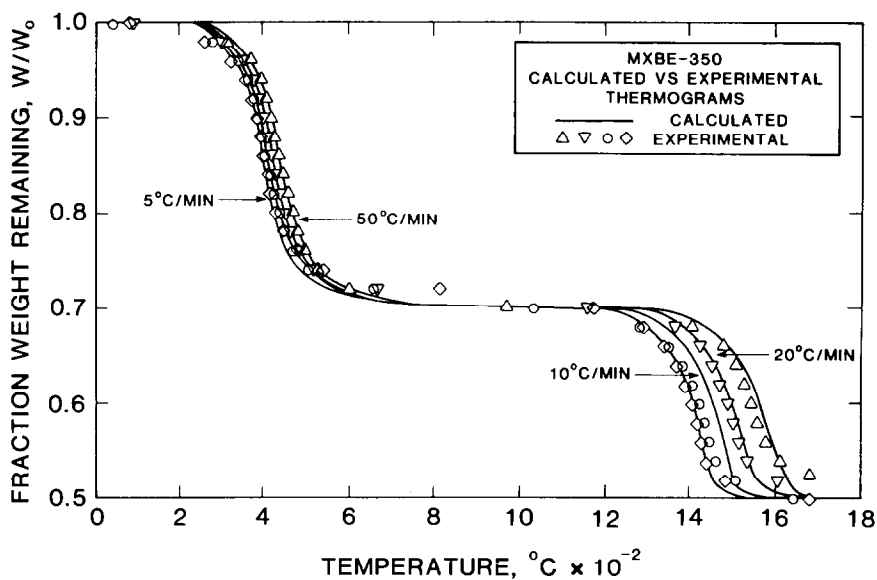

Fig. 5. Comparison of calculated vs. experimental thermograms.

are required to produce a hard copy and plots of the interpolated data from a TGA run. Also the interpolation routine converts and interpolates the data to a much greater accuracy than can be obtained from strip charts.

The system is also quite versatile. The 40 channels of input on the data logger allow several different experiments to be connected to the system simultaneously. This is an advantage in laboratories where different and unrelated experiments are being conducted. The system can also be expanded to accommodate different thermal analysis components, such as a differential scanning calorimeter (DSC), simply by modifying or adding to the software. These features give this data acquisition system a significant advantage over most of those currently available for use with thermal analysis equipment.

Finally, the cost of the data acquisition system is quite reasonable. The entire unit can be assembled for approximately one half the cost of some data acquisition systems marketed with thermal analysis equipment.

## REFERENCES

- 1 Instruction Manual, 9302/Apple Microcomputer Support Manual, Monitor Labs, San Diego, CA, 1980.
- 2 J.B. Henderson, J.A. Wiebelt, M.R. Tant and G.R. Moore, *Thermochim. Acta*, 44 (1981) 253.
- 3 J.B. Henderson and M.R. Tant, *Polym. Comp.*, 4 (1983) 233.
- 4 H.L. Friedman, *J. Polym. Sci., Part C*, 6 (1965) 183.